

Conveyors



Key Benefits -

- Customized to handle your bulk materials' particular weights and densities
- Standalone or integrated unit
- Direct drive system
- Prebuilt modular conveyor sections that can be quickly coupled together
- Variety of speed ranges available to meet your requirement
- Three emergency shutdown features

6" - 20" Sizes Available

UL / ATEX Certified



Features -

- All conveyor fitted with components manufactured to CEMA standards
- Heavy-duty 3/16" mild steel plate coated with two part grey primer paint (painted to customer color code if required)
- Shafts are manufactured from cold rolled steel
- Modules supplied fully assembled
- 12Ft Conveyors can be quickly and easily extended by adding 6 ft and 12 ft extension modules
- Enhanced safety options

PSI Pivoting Conveyor Boom

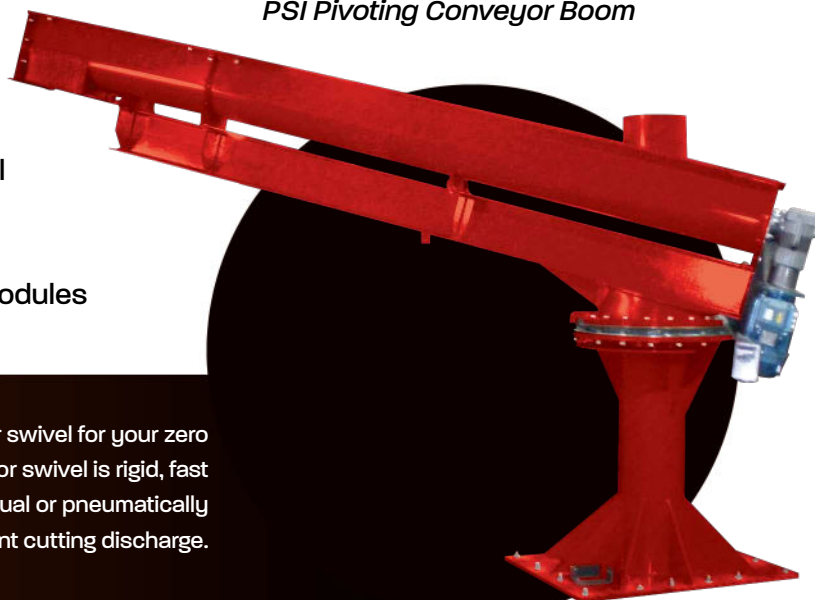

Inquire about our 360° conveyor swivel for your zero discharge application. Our conveyor swivel is rigid, fast acting, safe, and easy to use. Manual or pneumatically operated allows for clean and efficient cutting discharge.

PSI Conveyors

Problem Solving-

PSI works closely with customers to find efficient solutions to challenging applications.

The following are some examples:

- Swivel pedestal conveyors, manually or hydraulically actuated
- Swivel discharges and chutes that can be rotated through 360°
- Manually or pneumatically actuated slide gate discharges allowing for multiple discharges on one conveyor
- Angled conveyors allowing one conveyor to convey both horizontally and inclined
- Brake motors for instantaneous stopping of the drive unit

Modules

- 6Ft and 12Ft standard pre-built modules
- Final conveyor length of 6Ft, 12Ft, 18Ft, etc. can be quickly and easily constructed
- Other lengths available on request
- Solid or GRP Grating top covers

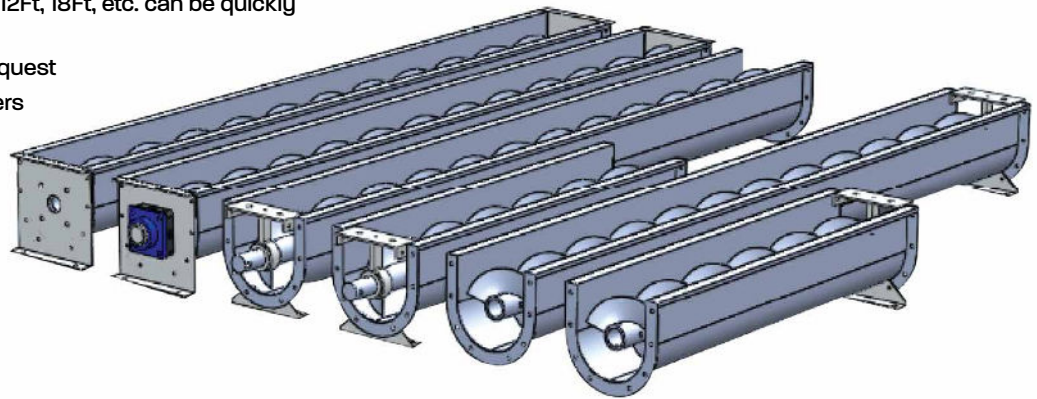

Drives

Three types of drive units are available:

- Fixed speed helical in line
- Fixed speed helical bevel right angle drive
- Variable speed helical in line with mechanical variator

UL Explosion proof or ATEX/IECex



PSI has direct drive systems thus eliminating the necessity to hold inventory of replacement sheaves, bushes and belts for the old belt drive systems. Direct drives are also more HSE friendly as there are no moving parts that fingers can get trapped in or belt guards that require maintenance to ensure safety.



UL / ATEX Certified

Auxiliary Products

Emergency Shut-Down Devices

Emergency shutdown abilities enhance the safety and/or overall performance of the equipment.



Grab Wire Switch

An ATEX/IECex Grab wire switch is a simple device that is connected to the conveyor electric motor starter and is activated by pulling on the grab wire. The grab wire cable should be conveniently located as close to the conveyor as possible to enable easy access. It has to be manually reset before the conveyor can be restarted.



Emergency Stop Button

As with the grab wire switch, an ATEX/IECex emergency stop button is connected to the conveyor electric motor starter. It should be located at the opposite end to the starter giving more shut down options. As with the grab wire switch, it has to be manually reset before the conveyor can be restarted.



Beacon/Siren Combination Unit

An ATEX/IECex combination beacon and siren unit is used in conjunction with the delayed start starter. When the start button is pushed, the beacon and siren unit will be activated giving and audible and visual warning that the conveyor is about to start.

Safety Grates

Solid plate steel or GRP grating top covers

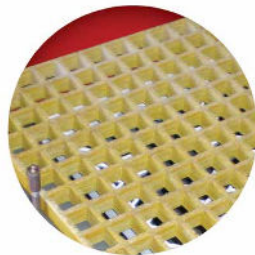

DOL Starters

The PSI range of ATEX/IECex Certified DOL (Direct On Line) Starters all come with a 110V control transformer for connecting auxiliary emergency stop devices and a lockable isolator switch as standard.

Three standard types are available:

Standard ATEX/IECex Starter with start and stop buttons, 110V control transformer with connections for two auxiliary emergency stop devices, lockable isolator switch

Forward and Reverse ATEX/IECex Starter with start, stop and reverse buttons, 110V control transformer with connections for two auxiliary emergency stop devices, lockable isolator switch

Delayed start ATEX/IECex Starter with start and stop buttons, adjustable delayed start function with connection for a beacon / siren combination unit, 110V control transformer with connections for two auxiliary emergency stop devices, lockable isolator switch.

Custom Built Panels

PSI offer custom built control panels to control two or more conveyors from one unit. Available with all the features of our standard single starters, built to individual requirements and specifications.



For more information on our products, Please contact us at 7519 Prairie Oak Drive Houston, TX 77086
Local 281-893-4774 | (866) 866-4PSI (4774) | Fax 281-893-1027 www.PSIMAX2000.com





Process Solutions International™

No matter the processing problem, PSI has the solution.



Toll-Free (866) 866-4PSI WWW.PSIMAX2000.COM

Download our full line of
INSTALLATION, OPERATION & MAINTENANCE MANUALS
at www.psimax2000.com



In short, screw conveyors offer a highly efficient, consistent and reliable way of moving bulk materials horizontally or at an incline. The swivel boom feature allows for precise offloading, and PSI's multiple safety features maximize personnel protection and reduce maintenance costs.