

Hydrocyclone Desander



PSI hydrocyclone units deliver efficient, economical and dependable services for separation of solid-phase particles in the drilling fluid. Built on a easily moved skid, the units include mud trough, manifold, polyurethane hydrocyclones, pressure gauge and all necessary connections.

Key Benefits -

- 10" hydrocyclone available
- 1 to 3 cone headers options
- Vertical or slant mount units to meet your height restrictions
- Removes sand-size solids (40-50 microns)
- Highly resistant to heat and abrasion
- Economical, long-lasting upgrade



Features -

- Single, dual or triple cone units
- Each 10" cone processes 500 GPM
- Rugged 95 Shore A durometer polyurethane construction
- Clamp type for fast, easy cleaning break-down
- Shipped fully assembled, ready for installation

Molded from rugged 95 Shore A durometer polyurethane for dependable, long-lasting performance, the unit offers exceptional resistance to heat and abrasion. There are no problematic moving parts to jam or wear. The bottom cone and discharge assembly are easily removed for cleaning or replacement.



Hydrocyclone Desander

Problem Solving-

The PSI 10" hydrocyclone desander is a cost-effective equipment upgrade designed to efficiently remove sand-size (40-50 micron) particles from drilling fluids. Operating at 75 ft lbs of pressure, the unit processes approximately 500 gallons of fluid per minute, per cone.

DETAILS DIMENSIONS / FRONT / SIDE / TOP

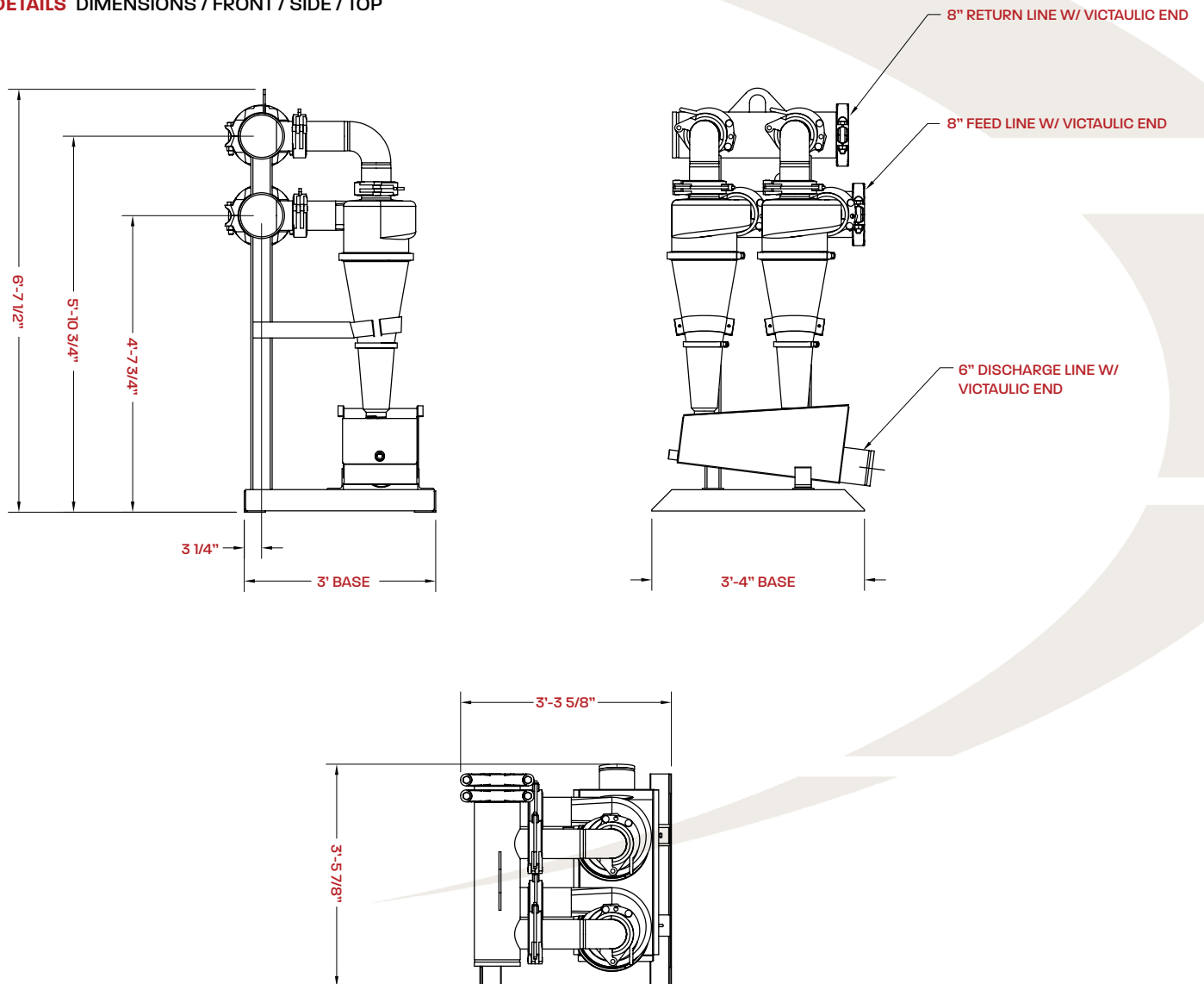

In short, for easy installation and maintenance, long-wearing durability and dependable performance makes the PSI 10" hydrocyclone desander the ideal equipment upgrade for demanding drilling projects.