



Process Solutions International™

No matter the processing problem, PSI has the solution.

MAX2000® Fuel Filtration System



Prolong system life and evade income loss with the MAX2000® Fuel Filtration System. It eliminates fuel contaminants like water, sediment and even algae growth that can potentially cause flow and ignition problems. Avoid significant downtime and expensive repairs using PSI's filtration system that pumps clean, quality fuel.

Key Benefits -

- Equipped with a backup pump; expect no downtime
- At just 35 psi, the unit removes 100% of water and 98% of dirt and other contaminants
- Equipped with a rotary gear pump delivering up to 55 gpm of processed fuel
- Explosion proof starters
- Driven by two explosion-proof electric motors
- Filter easily maintained; no replacement filters needed

Features -

- 11 to 50 gpm units available
- Heavy wall plumbing
- Valves and plumbing for independent operation
- Dual-stage filtration
- Two explosion-proof electric motors
- Available with dispensing hose and nozzle
- Skid mounted w/ catch pan
- Finished with a durable polyurethane paint
- Shipped fully assembled

Having a backup gear pump in the MAX2000® Fuel Filtration System avoids the loss of expensive downtime.

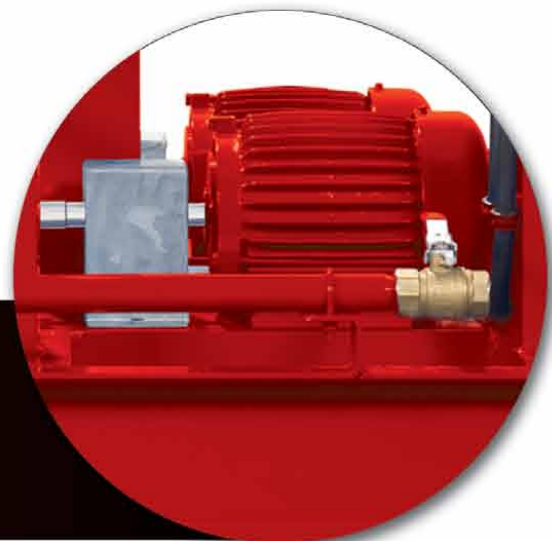

For more information on our products, Please contact us at 7519 Prairie Oak Drive Houston, TX 77086
Local 281-893-4774 | (866) 866-4PSI (4774) | Fax 281-893-1027 www.PSIMAX2000.com

ISO 9001:2008

MAX2000® Fuel Filtration System

Problem Solving-

The MAX2000® Fuel Filtration System cleans with excellence, removing all the fuel contaminants that can clog up the pump and temporarily shut down a project. Because fuel is pumped swiftly, you need a filtration system that can filter liquids and remove water at the same fast pace.

Oilfield equipment depends on clean, pure fuel, and our dual-stage filtration system filters out all of your water and 98% of all other contaminants, giving you efficient operations in demanding conditions. Our filter is easily maintained, eliminating the need for replacement filters, and our USA made parts contribute to your having a durable and longer-lasting piece of equipment on the field.



The MAX2000® Fuel Filtration System comes equipped with explosion proof starters housing the unit switches and connections for safe operation

DETAILS ISOMETRIC / FRONT / SIDES / TOP

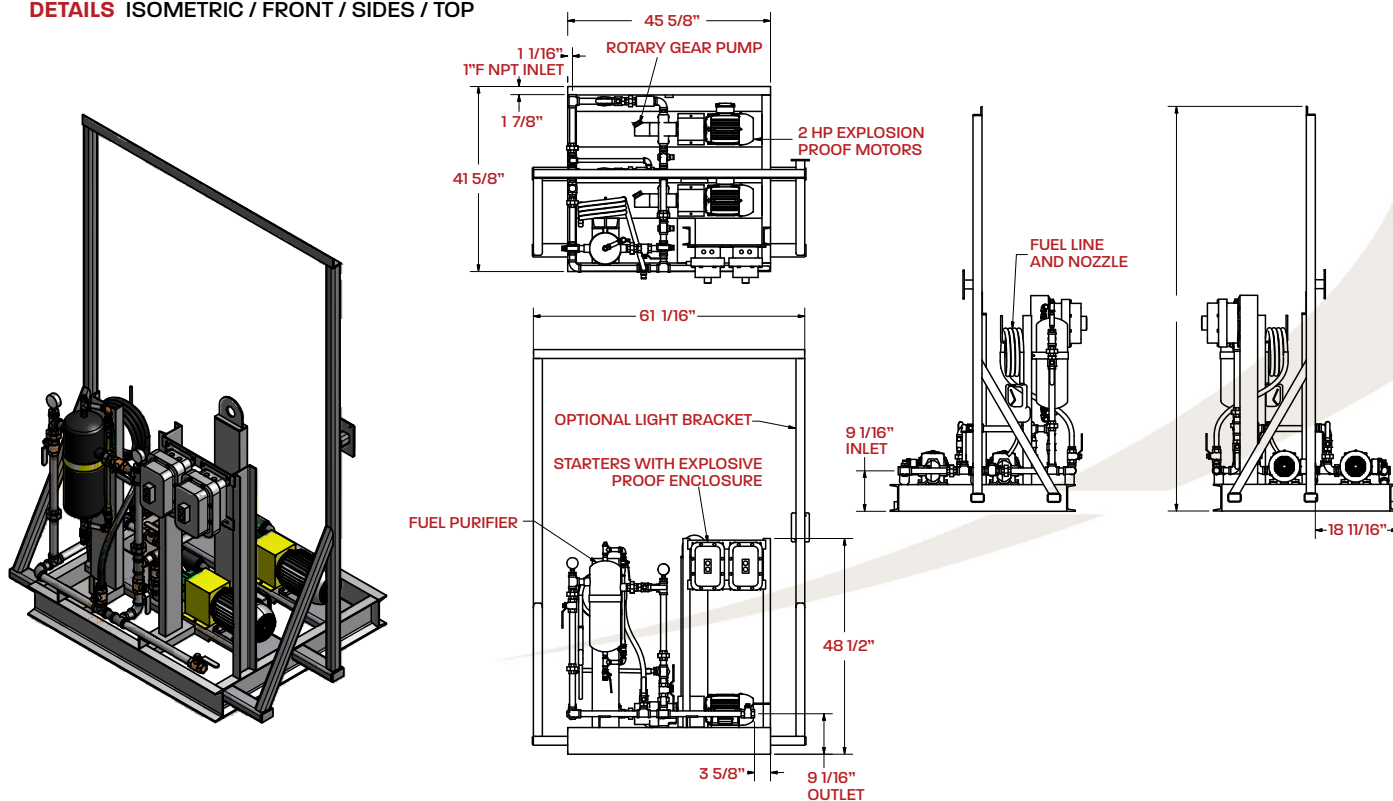

In short, the MAX2000® Fuel Filtration System offers a highly efficient and reliable way of filtering fuel until it's practically free of contaminants. The back-up pump ensures no downtime — thereby reducing income loss, and the explosion-proof starters and motors maximize personnel protection in challenging settings.